

## 19 mm and 25 mm OxyProbe® Membrane Cartridge

### STEP 1

While holding the membrane cartridge upright (with opening up) in one hand, carefully pour the electrolyte from the bottle into the cartridge until approximately 75% full. Remove any entrapped air bubbles by tapping on the side of the membrane housing. Try not to spill any of the electrolyte and be certain to wipe off any excess electrolyte with a clean tissue from the outside surfaces of the cartridge.

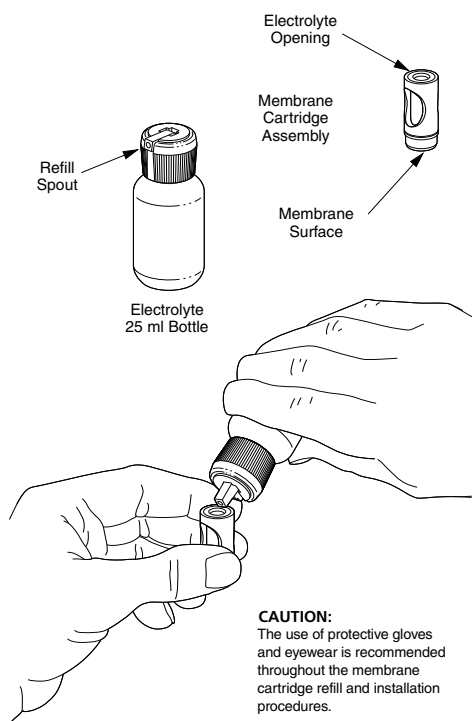

### STEP 2

In one hand, grip the membrane cartridge, which has been properly filled with electrolyte, by the thumb and forefinger slots while holding the sensor body with the other hand as shown.

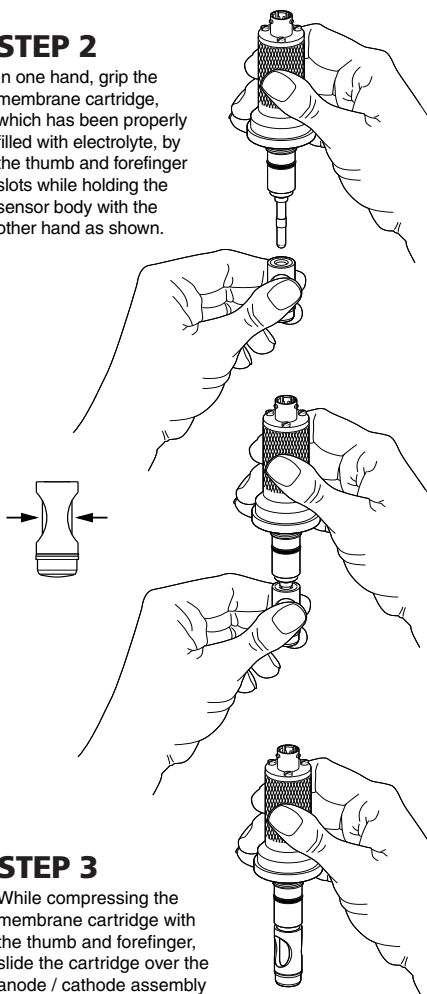

### STEP 3

While compressing the membrane cartridge with the thumb and forefinger, slide the cartridge over the anode / cathode assembly until the cartridge seats against the conical gasket. Release the pressure from the thumb and forefinger. Rinse lower portion of this subassembly with DI water to remove any excess electrolyte and blot dry with a clean tissue.

### STEP 4

The sensor body subassembly with the membrane cartridge in place is now ready for the installation of the stainless steel sensor sleeve.

### STEP 5

Slide the stainless steel sensor sleeve over the membrane cartridge, being careful not to nick the o-rings. Be certain that the mating threads of the sleeve and sensor body are free of any dirt or debris.

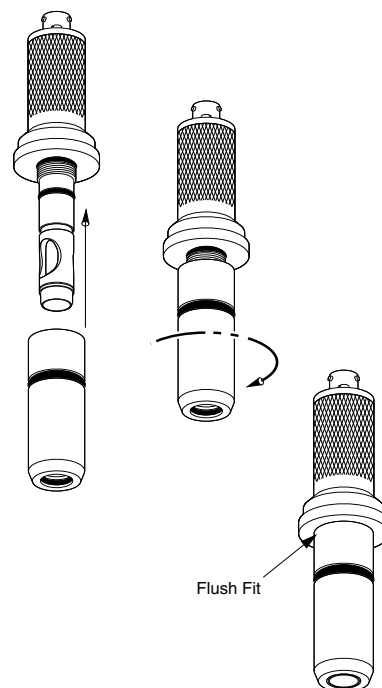

### STEP 6

Thread the stainless steel sensor sleeve onto the sensor body in the direction shown by the arrow. Be certain that the sleeve is flush with the sensor body so that no o-rings are visible. **Do not overtighten.** Hand tight is all that is necessary.

**Note:** Carefully inspect all o-rings and the conical gasket for any physical damage or excessive wear. Replace these items as needed or if there is any doubt as to their condition.

Measurement and Control Products for Science and Industry

19 Thomas, Irvine, California 92618 USA

Phone: (949) 829-5555 Toll-Free: (800) 288-2833 Fax: (949) 829-5560

E-Mail: sales@broadleyjames.com Website: www.broadleyjames.com

**BROADLEY  
JAMES  
CORPORATION**